



SSM InfoTech Solutions Pvt. Ltd.



“You Dream it, We Do It”



Capabilities

- Introduction
- Our People
- Product Exposure
- Industry Exposure and experience
- Projects executed in various areas
- Consulting and audits
- Credentials and awards



Founded in 2001



250+ Employees



Unique Solutions Covering
Automation *IT* *Software*



More than 560 Happy Customers





Customer References – Only few we can list here...

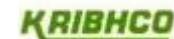

Golden assets for technology company

OUR PEOPLE – OUR TEAM



65+ Certified Wonderware Developers



Certified Training Centre and Certified trainer



Established Support System over phone, e-mail, remote desktop



Experienced in handling design, Engineering, development and support for large and critical projects



Well acquainted system to work as back-end/ off-site multi disciplined team from different regions and languages

Knowledge that counts on

PRODUCT EXPOSURE



InTouch



MES - Operations



System Platform



MES - Performance

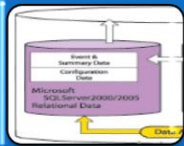

Historian and Information Portal

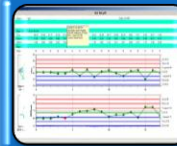

MES - Quality



Skelta Work Flow



Enterprise Integrator



In-Batch



Smart Glance

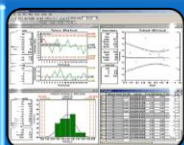

QI analyst



Dream Reports



Product	Total	Certified	Certified Trainer
InTouch	40	30+	2
ArchestrA System Platform	40	20+	2
Historian and Information Portal	20	15+	2
InBatch	10	8	2
QI Analyst	10	3	1
MES	8	5	1
Skelta Workflow	10	4	1
Dream Reports	4	0	0
InSight	2	0	0
Toolkits and Core Developers	20	2	0

Wide experience in various verticals

INDUSTRY EXPOSURE



Oil and Gas,
Piepline



Power
Sector



Water and
Waste Water



Chemical



Food and FMCG

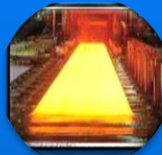

Metals



Manufacturing



Utilities and
Terminal
Automation



Experience can not be injected...

PROJECT EXECUTION EXPERIENCE



Project Experience

Food

Colgate India (50K Tag)

- Wonderware System Platform
- InBatch
- MES

Oil & Gas

Reliance Petroleum (1 M Tag)

- Fire and Gas SCADA with 12 Redundant server pair
- More than 120 InTouch/System Platform/ Historian
- Utilities

Mfg

Gujarat State Fertilizers (5K Tag)

- Data centralization and Utilities Management SCADA, collecting data from 129 geographical locations.

TAS

Indian Oil Corporation (25K Tag)

- Terminal Automaton System with System Platform and Historian
- Custom driver development, Integrated with batch Management System

Power

Lanco Power (5K Tag)

- Data Centralization – Historian. Collecting data from 4 power plants to head office.
- Information portal, Dashboards and reporting.

Consulting and audits ...

IN FIELD EXPERIENCE IN DESIGN

Food

Nestle India Limited

- Audit of Network systems
- Audit of Wonderware Applications and communications

Oil & Gas

Reliance Industries F&G system (Part of Project)

- Design and Engineering of Wonderware SCADA with 1 M devices, Network with more than 70 Redundant PLC, 150 Switches of redundant network.
- Audit and Issue resolution for network communication and Server Loading.

FMCG

Colgate India (Part of project)

- Design and implementation of Virtualization with 3 different networks, 2 physical server, 1 SAN etc.

TAS

Indian Oil Corporation (Part of Project)

- Design and review of Networking for redundant operation.
- Design and audit of custom software developed by OEM for correctness and functionality.

Proud to show our

SUCCESS STORIES

Reliance Hazira, ETP Plant

- First ever installation of System Platform in 2003
- More than 10,000 physical IOs.
- Dual redundant networks, servers and PLC controllers.
- Turn key project execution.
- Web reporting to provide excellent reporting system.
- OPC connectivity with aspen-tech historian.

ETP AUTOMATION NETWORK LAYOUT

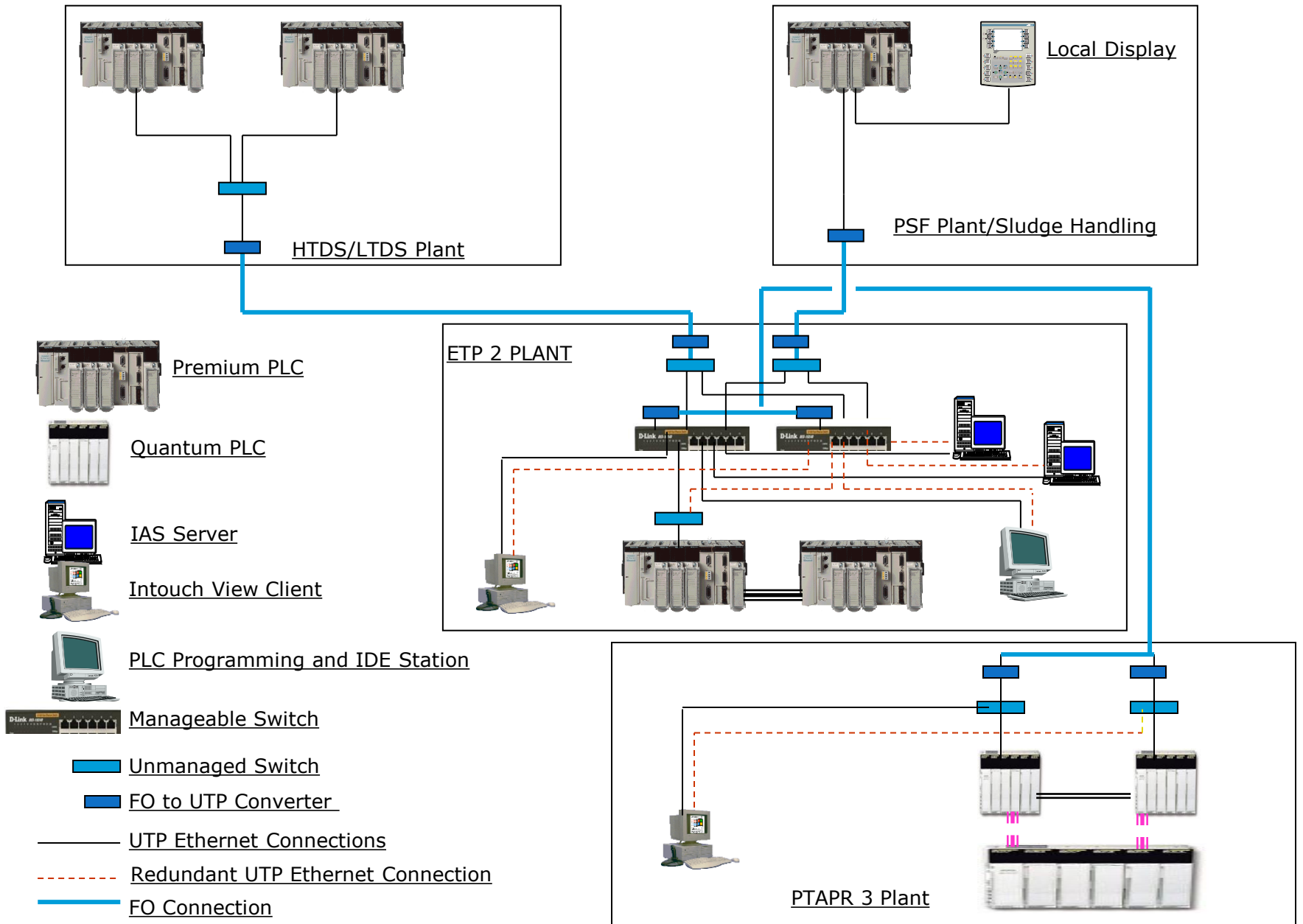

ONGC-Hazira, MIS and Historian

- Integration of 15 custody transfer meters, 3 DCS, 2 Wonderware nodes, 1 instromat ISS scada, 2 road weigh bridge and 1 rail weigh bridge.
- Special driver development of gas meters.
- Wonderware historian in redundant mode, 3 active factory clients and 2 data acquisition servers.
- Web reporting to provide excellent reporting system.
- OPC Gateway and SAP integration.

ONGC- Hazira, MIS system with wonderware Historian

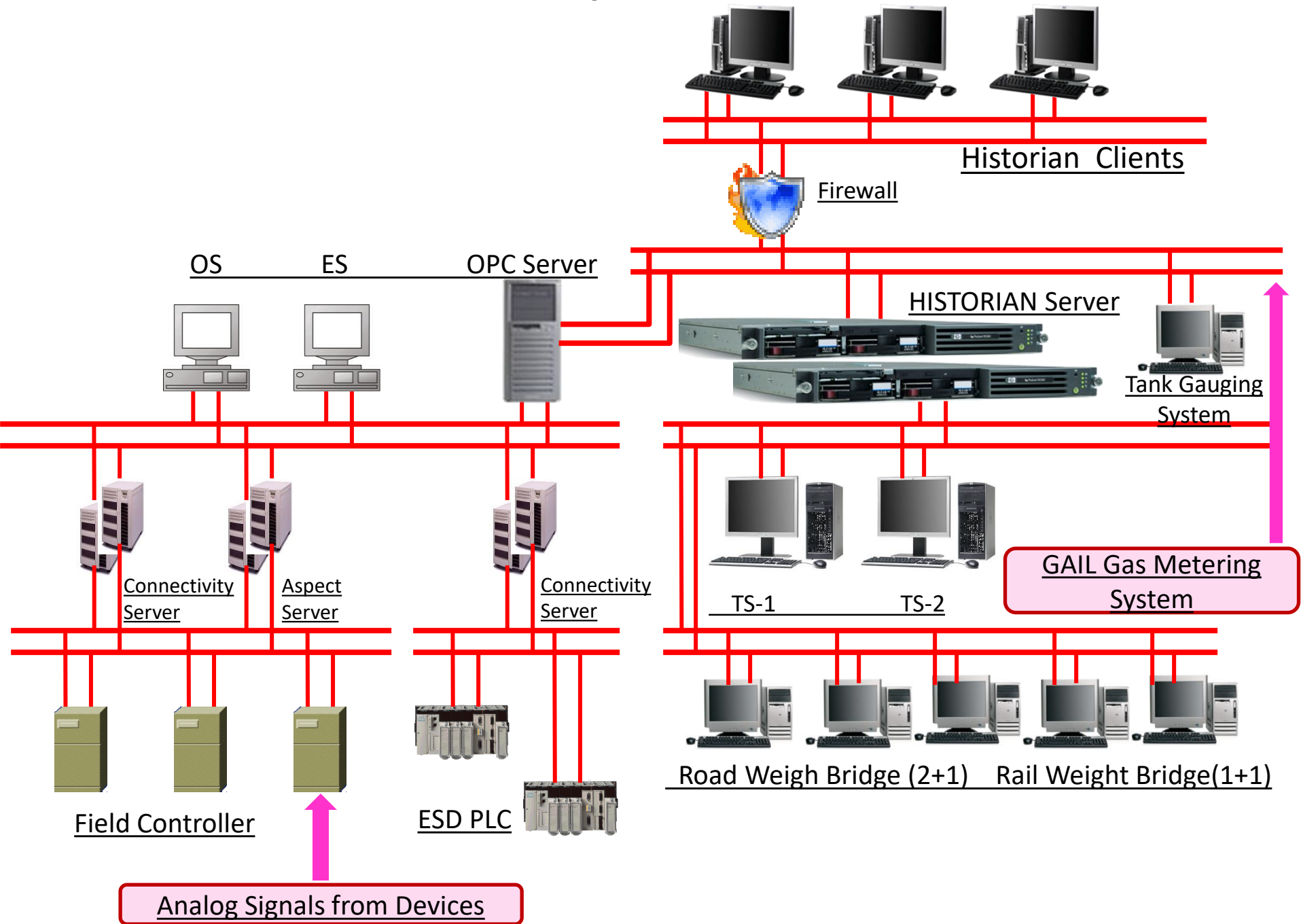

Reliance Jamnagar Refinery Fire SCADA

- Wonderware System Platform : 1 Million tag galaxy
- Redundant Application servers : 16 Location
- Specific network topology with two separate ring of network.
- X-Force Alarm and Information management system.
- NMS and its integration with Wonderware SCADA.
- Custom development of various control for alarm grid.
- Integration of PA system over Modbus – TCP Master.

System Layout

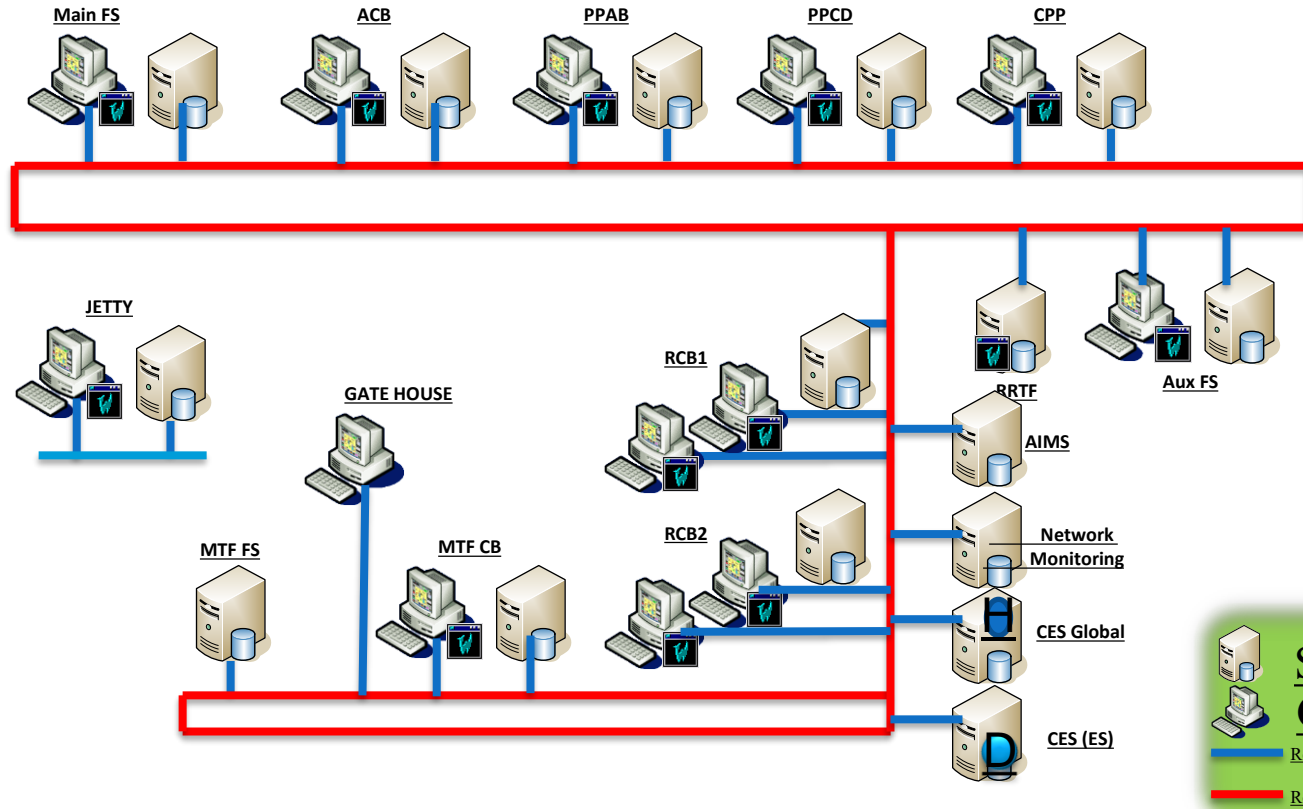

Screen Samples



FZ842D BERTH-D [OVERVIEW]

28-Dec-2012
14:55:10
None

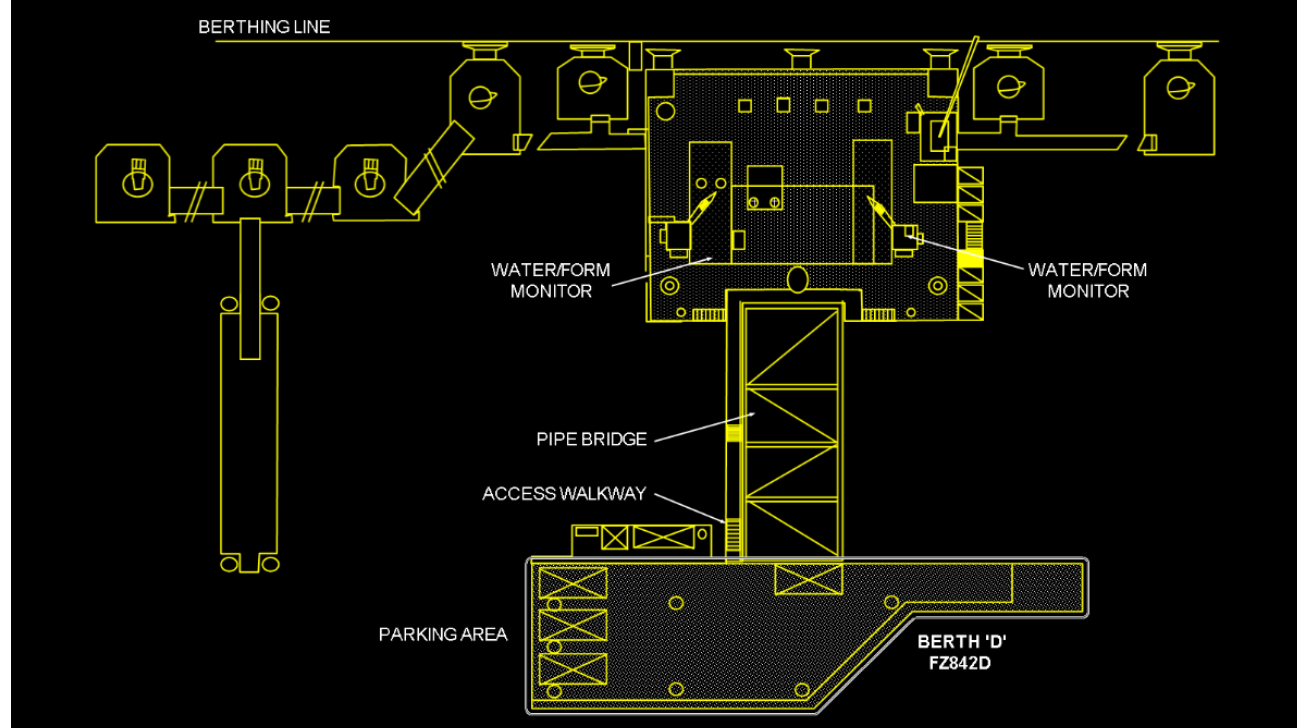

There are no items to show in this view.

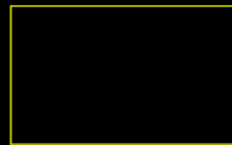
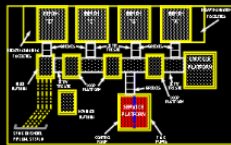

Area : FZ842 - D

[F10] Alarm Log [F11] History Log



[F12] Visible Tags System Reset

TagName :

APPLY REMOVE Cancel

Gujarat Fertilizer – MIS System

- Integration of sources using Moxa Data concentrators with 4 GB Storage, 70 Degree Temperature rating and GPRS and Ethernet connectivity.
- Rockwell PLC with specific programming for data concentration, Ethernet and GPRS connectivity.
- Wonderware System Platform Software with 2 redundant servers connected with 2 Client systems, high availability 2 Mbps Internet connections.
- X-Force Reporting System with dynamic reports and Mobile solution.
- Collecting data from 116 different locations.

Solution – System Layout – Control room

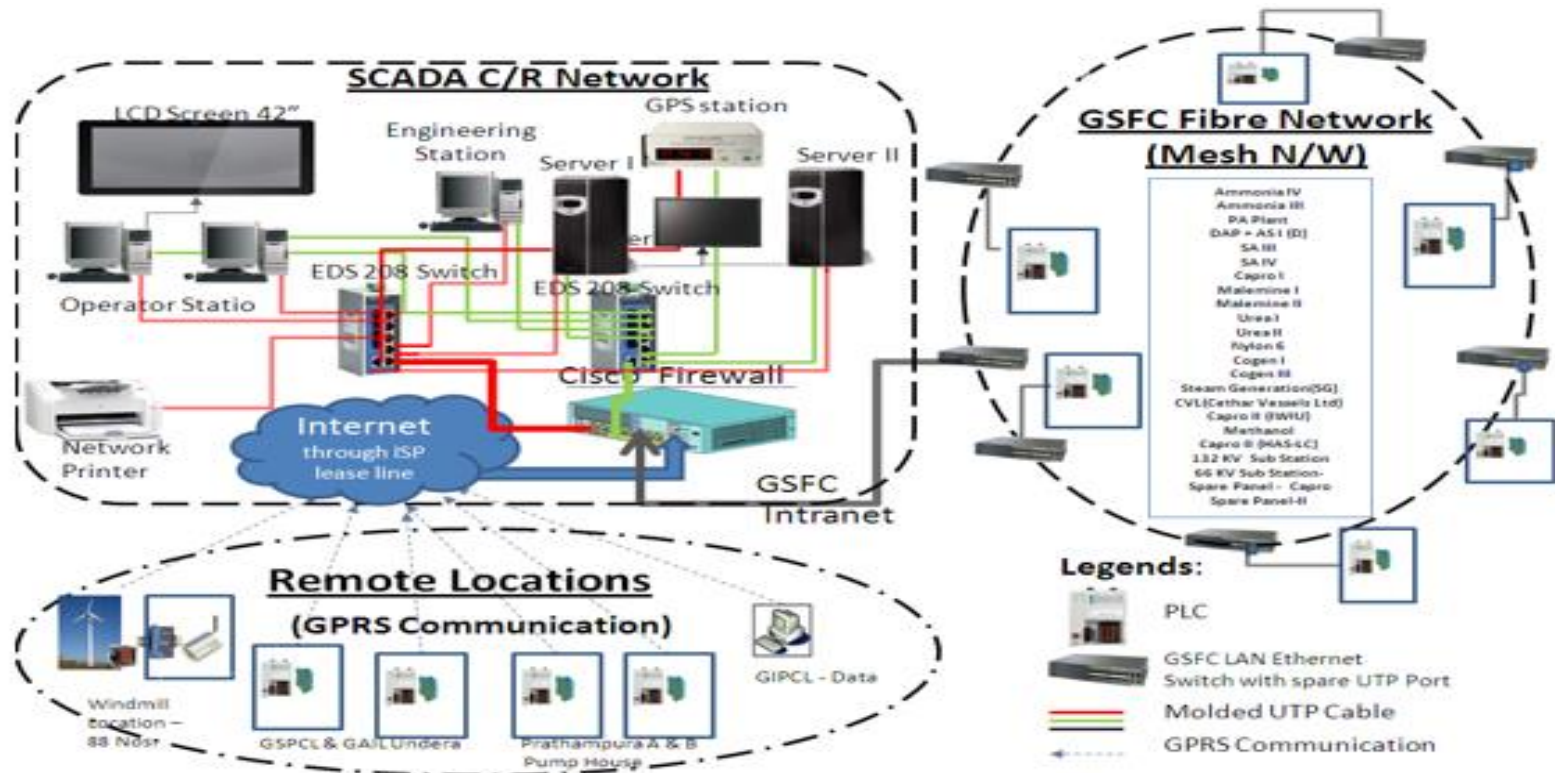

Benefits – Central Control room

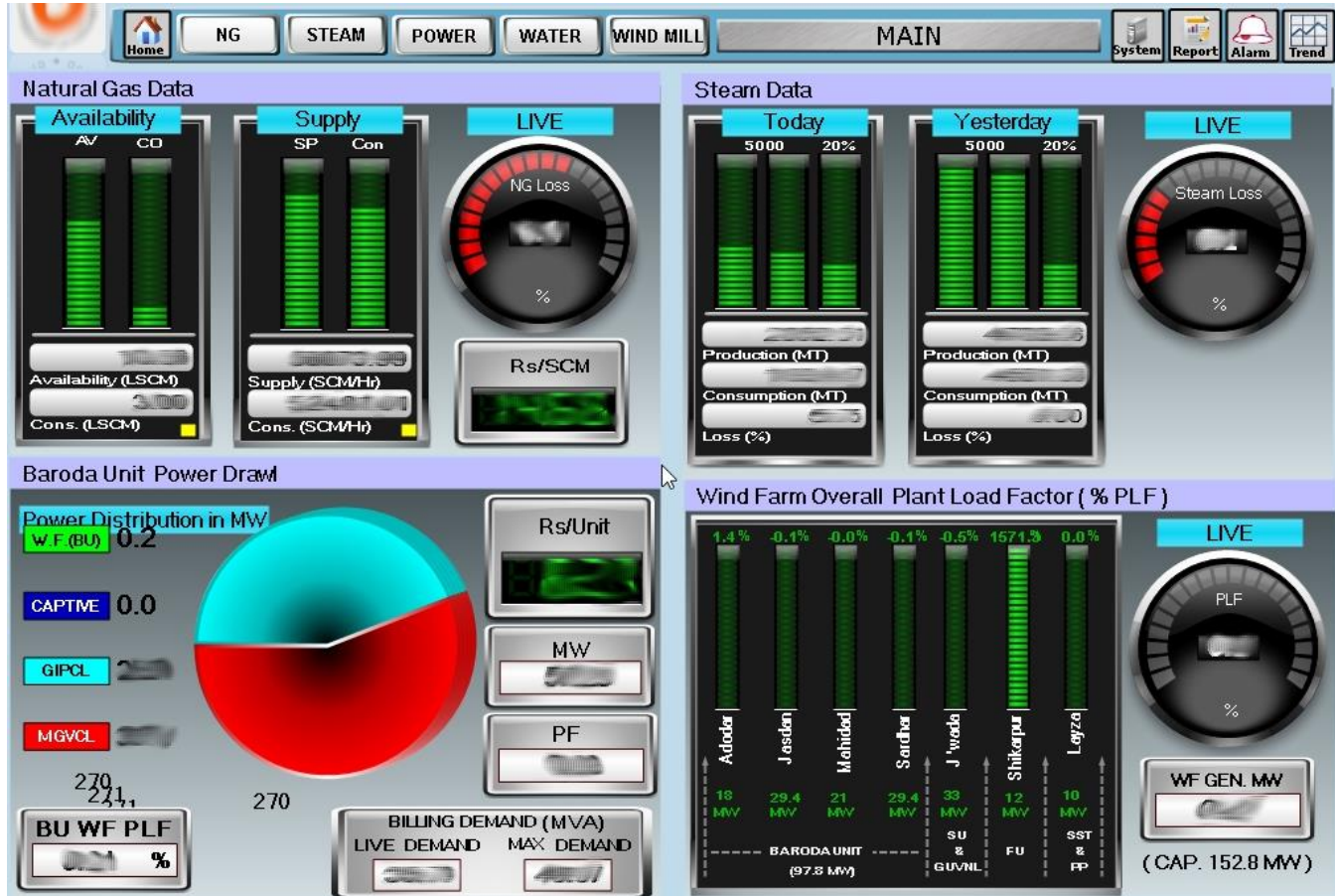

ITC Biscuit Factor MES

- Wonderware System Platform as automation platform
- Wonderware MES Operations
- Wonderware MES Performance
- Quality data collection using WSP
- 25 Nos. HMI for digitalization of workflow and work order execution
- Wonderware Historian and Information Portal for reporting
- 2 Nos. Big screen on shop floor to show KPI and current status.

System Layout

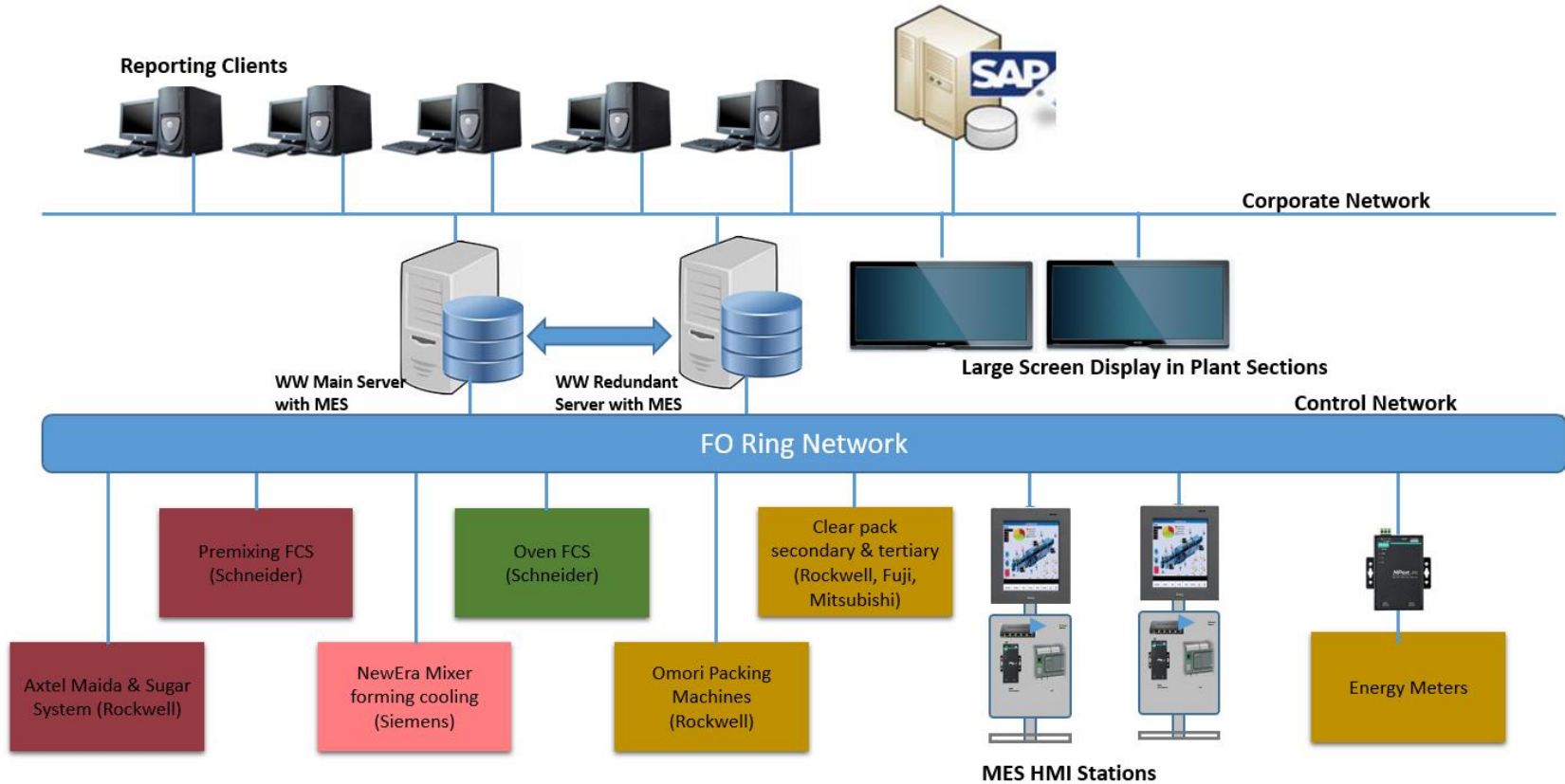

Proud to show our

CREDENTIALS AND AWARDS

Wonderware Journey till date

- Associated with Wonderware (20+ years) since 1st Installation of Software in India
- Distributorship experience : 5+ years
- Wonderware Partner : 13+ years
- Wonderware Certified Engineers (CSP) : 65+ People
- Total Wonderware portfolio Head Count : Close to 100 people
- Certified Training Center and Trainer (Only CTP in India)
- Awarded *“Wonderware for having Highest certified engineers in Asia Pacific”*
- Built Robust customer support system (Phone/email/remote support)
- Wonderware Value added software services – providing end-to-end solutions

Award from Invensys Operations Management for 2012 Highest Total Current CSP Certifications – Asia





You can reach us at:
www.ssminfotech.com or
write to us on sachin@ssminfotech.com or
Call me on
9998823941